

Hex Washer Combo  
Hex Washer Square

HEAD DIMENSIONS

Fasteners By Design Inc.

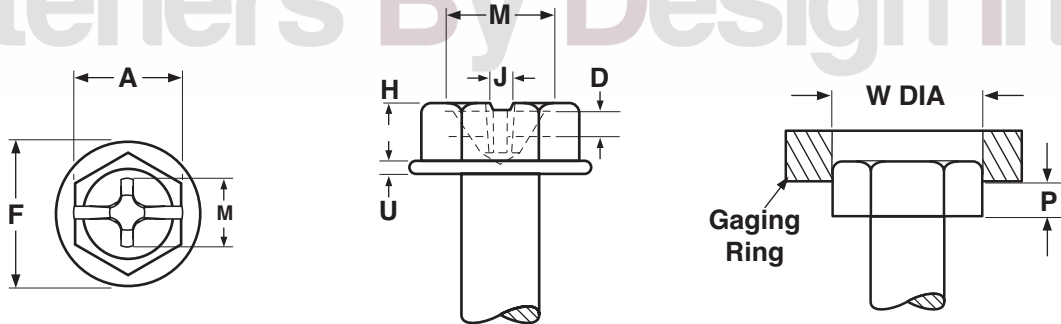

COMBINATION HEX WASHER HEADS																	ASME B18.6.3- 2013	
Nom Size	A		H		F		U		J		D		P	M	Recess Penetrating Gaging Depth		Phillips Driver Size	
	Width Across Flats		Head Height		Washer Diameter		Washer Thickness		Slot Width		Slot Depth		Protrusion Beyond Gaging Ring	Recess Diameter	Max	Min		
	Max	Min	Max	Min	Max	Min	Max	Min	Max	Min	Max	Min	Min	Ref				
6	.250	.244	.093	.080	.328	.302	.025	.015	.048	.039	.053	.033	.048	.148	.089	.064	2	
8	.250	.244	.110	.096	.348	.322	.031	.019	.054	.045	.074	.052	.058	.168	.115	.090	2	
10	.312	.305	.120	.105	.414	.384	.031	.019	.060	.050	.080	.057	.063	.178	.127	.102	2	
12	.312	.305	.155	.139	.432	.398	.039	.022	.067	.056	.103	.077	.083	.247	.152	.127	3	
1/4	.375	.367	.190	.172	.520	.480	.050	.030	.075	.064	.111	.083	.103	.277	.186	.161	3	

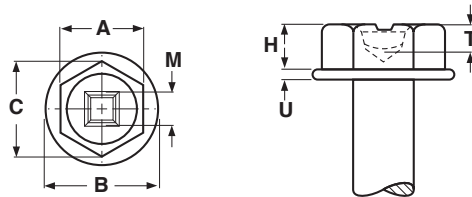

SQUARE RECESS HEX WASHER HEADS													
Nominal Size	A		C	H		B		U		M	T		Square Recess Size
	Width Across Flats		Width Across Corners	Head Height		Washer Diameter		Washer Thickness		Recess Diameter	Recess Penetration Gaging Depth		
	Max	Min	Min	Max	Min	Max	Min	Max	Min	Ref	Max	Min	
8	.250	.244	.272	.110	.096	.348	.322	.031	.019	.168	.085	.060	1

Fasteners By Design Inc.