

Fasteners By Design Inc.

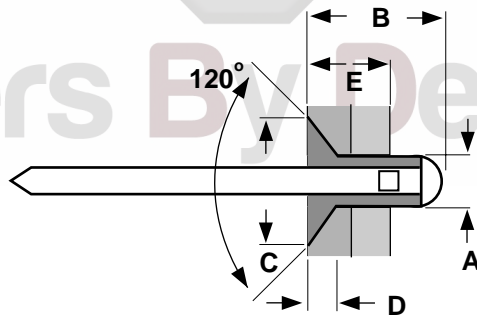

COUNTERSUNK MULTI-GRIP ALUMINUM BODY/STEEL MANDREL BLIND RIVETS											Avdel*
Part Number	A Rivet Diameter	B Length		C Head Diameter		D Head Height		E Grip Range	Recommended Hole Size	Shear Strength Pounds	Tensile Strength Pounds
		Max	Min	Max	Min	Max	Min				
		C-0412	1/8	.470	.410	.217	.198				
C-0414	1/8	.530	.480	.217	.198	.034	.026	.155-.312	.136	165	230
C-0416	1/8	.600	.530	.217	.198	.034	.026	.217-.375	.136	165	230
C-0514	5/32	.550	.490	.257	.238	.036	.028	.109-.312	.166	255	375
C-0615	3/16	.610	.520	.351	.343	.055	.047	.125-.312	.199	350	530
C-0621	3/16	.800	.710	.351	.343	.055	.047	.250-.500	.199	350	530

*Avdel Cherry Textron is the original writer of the multi-grip dimensions.

Description	An aluminum blind fastener with a self-contained steel mandrel. The multi-grip rivet design differs from a standard blind rivet two ways: (1) a section of the body shank has a slightly reduced outside diameter, and (2) the stem of the mandrel is pinched at a point above the mandrel head. The rivet's head is countersunk at an angle of 120°.
Applications/ Advantages	Multi-grip rivets provide maximum clamping action over a full range of material thicknesses while using the same rivet length. This allows flexibility in design, cuts production costs and reduces inventories. The countersunk head style provides a smooth offside surface and sufficient clearance for moving parts which pass over the rivet head. They should be used when fastening materials with mechanical and physical properties similar to aluminum.
Material	<i>Rivet:</i> Aluminum Alloy 5251 or equivalent alloy. <i>Mandrel:</i> Low carbon steel with a choice of coating: black phosphate or zinc with yellow chromate.
Shear Strength	Rivets shall have ultimate shear loads not less than the minimum ultimate shear loads specified for the applicable size given in the above table.
Tensile Strength	Rivets shall have ultimate tensile loads not less than the minimum ultimate tensile loads specified for the applicable size given in the above table.

PART NUMBER COMPARISON - COUNTERSUNK MULTI-GRIP RIVETS				
Kanebridge- Zinc yellow mandrel	Avdel Avex® - Zinc yellow mandrel	Kanebridge- Black phos mandrel	Avdel Avex® - Black phos mandrel	Pop® - Plain steel mandrel
C-0412Y	1682-0412	C-0412B	1604-0412	AK41-44BS
C-0414Y	1682-0414	C-0414B	1604-0414	-
C-0416Y	1682-0416	-	1604-0416	-
C-0514Y	1682-0514	-	1604-0514	-
C-0615Y	1682-0615	C-0615B	1604-0615	-
C-0621Y	1682-0621	C-0621B	1604-0621	-

©Pop is a registered trademark of Pop Fastening Systems, Emhart Fastening Technologies, a Black & Decker Company.

©Avex is a registered trademark of the Avdel Cherry Textron Corporation. Kanebridge's rivets are not manufactured by or connected with the producers of Avex® or Pop® rivets.