

Fasteners By Design Inc.

31FGS-SPLT

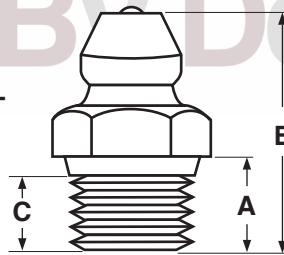

GREASE FITTING — SPL TAPER THREAD								
Part Number	Type	Thread	A	B	C	Recommended Hole Size		Hex Size Across the Flats
			Shank Length	Total Height	Effective Thread Length	Max	Min	Ref
			Ref	Ref	Ref			
31FGS-SPLT	Straight	1/4-28	13/64"	9/16"	9/64"	0.235	0.230	5/16"

Fasteners By Design Inc.

Description	A fastener that has external threads at one end a nipple-style connection at the opposite end. The nipple consists of an opening in which a small captive ball bearing maintains its location flush with the surface of the fitting by the force supplied by a retaining spring within the fitting.
Applications / Advantages	Used on mining, agricultural and industrial equipment when regularly scheduled lubrication maintenance is required to extend lifespan of machinery. Installation force causes material of untapped hole to reshape conforming to fitting thread contour, providing a leak proof permanent seal.
Material	Carbon Steel
Case Depth	0.13 - 0.23 mm
Case Hardness	Rockwell 15N 83 minimum
Plating	Parts are supplied RoHS zinc finish.

Fasteners By Design Inc.

Fasteners By Design Inc.

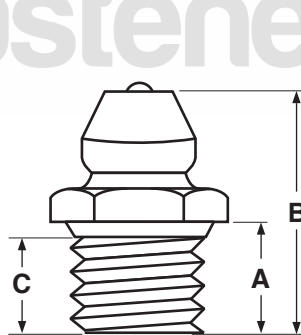

43FGS-SPL

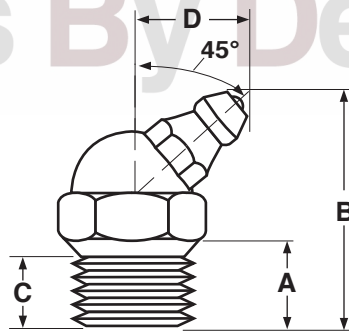

43FG45-SPL

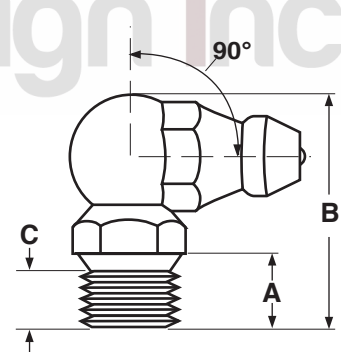

43FG90-SPL

GREASE FITTINGS — SPL PIPE THREAD

Part Number	Type	Thread	A	B	C	D	Recommended Hole Size		Hex Size Across the Flats
			Shank Length	Total Height	Effective Thread Length	Check Valve Distance	Max	Min	Ref
			Ref	Ref	Ref	Ref			
43FGS-SPL	Straight	1/8-27	15/64"	5/8"	9/64"	-	.380	.373	7/16"
43FG45-SPL	Elbow	1/8-27	13/64"	27/32"	11/64"	29/64"	.380	.373	7/16"
43FG90-SPL	Elbow	1/8-27	13/64"	3/4"	11/64"	17/32"	.380	.373	7/16"

Description	A fastener that has external threads at one end a nipple-style connection at the opposite end. The nipple consists of an opening in which a small captive ball bearing maintains its location flush with the surface of the fitting by the force supplied by a retaining spring within the fitting.
Applications / Advantages	Used on mining, agricultural and industrial equipment when regularly scheduled lubrication maintenance is required to extend lifespan of machinery. Installation force causes material of untapped hole to reshape conforming to fitting thread contour, providing a leak proof permanent seal.
Material	Carbon Steel
Case Depth	0.13 - 0.23 mm
Case Hardness	Rockwell 15N 83 minimum
Plating	Parts are supplied RoHS zinc finish.

Fasteners By Design Inc.

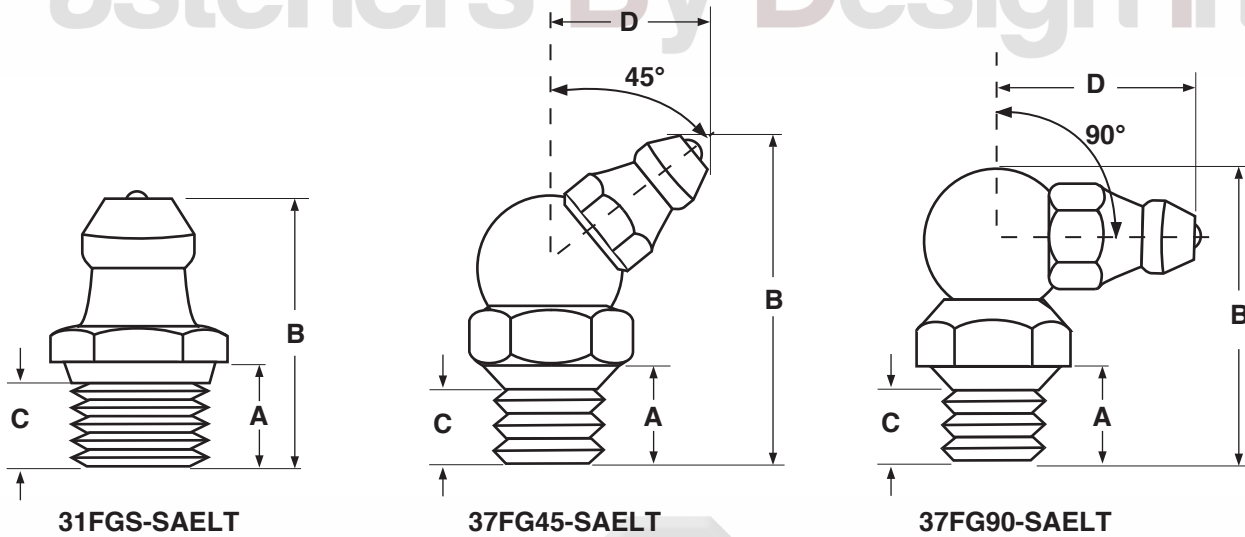

GREASE FITTINGS — SAE-LT TAPER THREAD							
Part Number	Type	Thread	A	B	C	D	Hex Size Across the Flats
			Shank Length	Total Height	Effective Thread Length	Check Valve Distance	
			Ref	Ref	Ref	Ref	
31FGS-SAE LT	Straight	1/4-28	3/16"	35/64"	9/64"	-	5/16"
37FG45-SAE LT	Elbow	1/4-28	7/32"	27/32"	5/32"	7/16"	3/8"
37FG90-SAE LT	Elbow	1/4-28	7/32"	3/4"	5/32"	33/64"	3/8"

Description	A fastener that has external threads at one end a nipple-style connection at the opposite end. The nipple consists of an opening in which a small captive ball bearing maintains its location flush with the surface of the fitting by the force supplied by a retaining spring within the fitting.
Applications / Advantages	Used on mining, agricultural and industrial equipment when regularly scheduled lubrication maintenance is required to extend lifespan of machinery. These fittings are designed to be installed into straight holes with 1/4-28" UNF 3B straight thread.
Material	Carbon Steel
Case Depth	0.13 - 0.23 mm
Case Hardness	Rockwell 15N 83 minimum
Plating	Parts are supplied RoHS zinc finish.

Fasteners By Design Inc.

Grease Fittings

Fasteners By Design Inc.

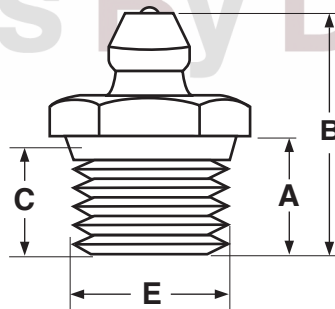

56FGS-PTF

GREASE FITTINGS — PTF PIPE THREAD							
Part Number	Type	Thread	A	B	C	E	Hex Size Across the Flats
			Shank Length	Total Height	Effective Thread Length	Thread Outside Diameter	
			Ref	Ref	Ref	Ref	
56FGS-PTF	Straight	1/4-18	3/8"	53/64"	19/64"	0.540"	9/16"

Description	A fastener that has external threads at one end a nipple-style connection at the opposite end. The nipple consists of an opening in which a small captive ball bearing maintains its location flush with the surface of the fitting by the force supplied by a retaining spring within the fitting.
Applications / Advantages	Used on mining, agricultural and industrial equipment when regularly scheduled lubrication maintenance is required to extend lifespan of machinery. These fittings are recommended where heavy lubricants are used.
Material	Carbon Steel
Case Depth	0.13 - 0.23 mm
Case Hardness	Rockwell 15N 83 minimum
Plating	Parts are supplied RoHS zinc finish.

Fasteners By Design Inc.