

Cap Screws & Bolts

12-Point Flange Screws

Alloy Steel

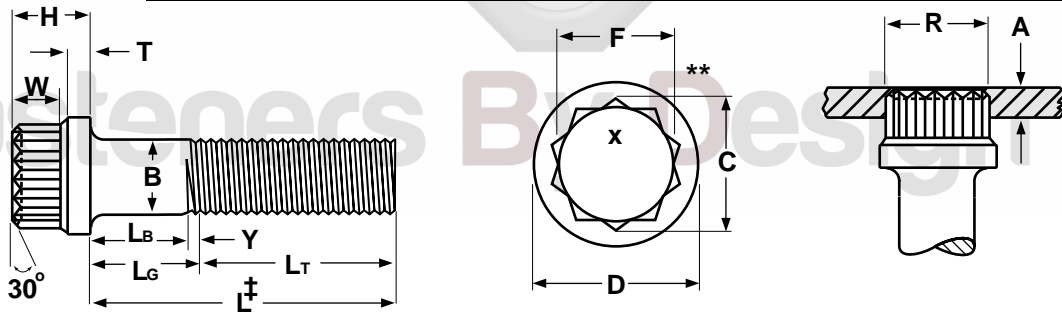

‡Length of a flange screw is measured from the underhead bearing surface to the extreme end of the screw.

12-POINT FLANGE SCREWS														IFI 115	
Nominal Size	B	D		F		C	H	W	T	A		R		L _T	Y
	Body Diam.	Flange Diam.		Width Across Flats		Width Across Corners	Head Height	Wrenching Height	Flange Thickness	Gaging Ring Thickness		Gaging Ring Diam.		Thread Length	Transition Thread Length
	Min	Max	Min	Max	Min	Max	Min	Max	Min	Min	Max	Min	Max	Min	Max
1/4	0.2435	0.375	0.365	0.252	0.244	0.278	0.260	0.15	0.058	0.0525	0.0522	0.2783	0.2780	1.000	0.25
5/16	0.3053	0.469	0.457	0.315	0.306	0.348	0.312	0.18	0.074	0.0600	0.0597	0.3483	0.3480	1.125	0.28
3/8	0.3678	0.562	0.550	0.377	0.368	0.420	0.375	0.21	0.095	0.0711	0.0708	0.4203	0.4200	1.250	0.31
7/16	0.4294	0.656	0.642	0.438	0.429	0.489	0.438	0.26	0.109	0.0840	0.0837	0.4893	0.4890	1.375	0.36
1/2	0.4919	0.750	0.735	0.502	0.493	0.562	0.500	0.29	0.129	0.0948	0.0945	0.5623	0.5620	1.500	0.38
9/16	0.5538	0.844	0.828	0.564	0.555	0.633	0.563	0.33	0.145	0.1071	0.1068	0.6333	0.6330	1.625	0.42
5/8	0.6163	0.938	0.921	0.627	0.618	0.705	0.625	0.36	0.166	0.1179	0.1176	0.7053	0.7050	1.750	0.46
3/4	0.7406	1.125	1.107	0.752	0.743	0.847	0.750	0.44	0.200	0.1416	0.1413	0.8473	0.8470	2.000	0.50
7/8	0.8647	1.312	1.293	0.877	0.866	0.987	0.875	0.51	0.234	0.1656	0.1653	0.9873	0.9870	2.250	0.56
1	0.9886	1.500	1.479	1.003	0.991	1.130	1.000	0.60	0.268	0.1893	0.1890	1.1303	1.1300	2.500	0.62
1-1/8	1.1086	1.688	1.665	1.128	1.115	1.271	1.125	0.66	0.310	0.2109	0.2106	1.2713	1.2710	2.750	0.71
1-1/4	1.2336	1.875	1.852	1.253	1.240	1.414	1.250	0.73	0.350	0.2331	0.2328	1.4143	1.4140	3.000	0.71
1-3/8	1.3568	2.062	2.038	1.378	1.365	1.556	1.375	0.80	0.392	0.2544	0.2541	1.5563	1.5560	3.250	0.83
1-1/2	1.4818	2.250	2.224	1.503	1.489	1.697	1.500	0.87	0.433	0.2763	0.2760	1.6973	1.6970	3.500	0.83

Tolerance on Length	Nominal Screw Lengths			
	Up to 1 in., incl.	Over 1 to 2 in., incl.	over 2 to 6 in., incl.	over 6 in.
	-0.031	-0.047	-0.062	-0.125

Description	A one-piece bolt with a 24-sided head and a flanged bearing surface, made of alloy steel.
Applications/Advantages	Popular in aircraft manufacturing and aftermarket because of its ease of installation with pneumatic wrenches.
Material	Alloy Steel
Heat Treatment	Grade-8 flange screws shall be heat treated, oil quenched and tempered at a minimum tempering temperature of 800°F.
Hardness	Rockwell C37 - 43
Tensile Strength	170,000 psi. minimum
Yield Strength	158,000 psi. minimum
Proof Load	135,000 psi.
Plating	See Appendix-A for plating information.

**Product standards require the manufacturer's head marking to appear on the top of all bolts 1/4" diameter and larger. "X" represents one location such a marking may appear.